

FRONT VIEW

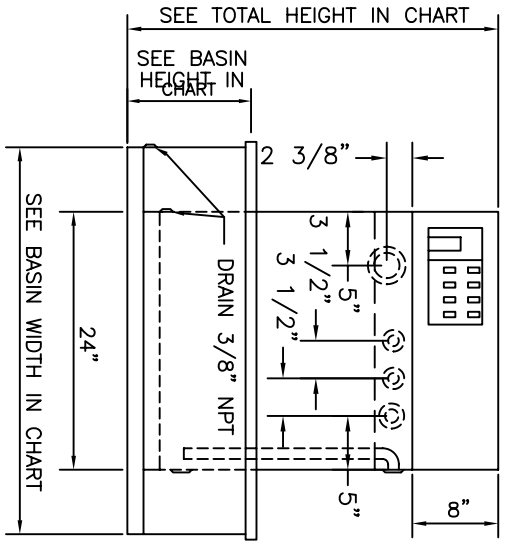

RIGHT SIDE VIEW

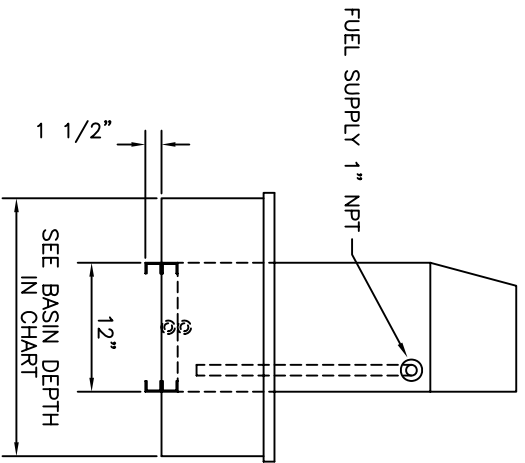

REAR VIEW

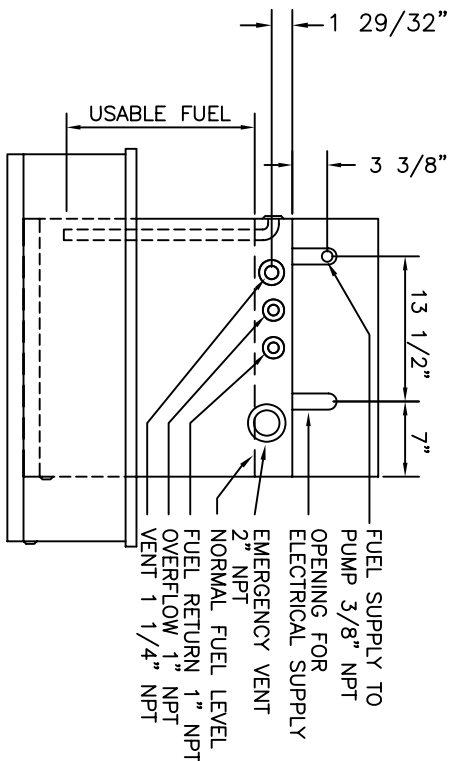

	MODEL		
	DT10	DT15	DT25
CAPACITY	GAL. 10	15	25
	LIT. 38	57	95
BASIN WIDTH	IN 32	32	32
	CM 81.3	81.3	81.3
BASIN DEPTH	IN 20	20	20
	CM 50.4	50.4	50.4
TANK WIDTH	IN 24	24	24
	CM 61	61	61
TANK DEPTH	IN 12	12	12
	CM 30.5	30.5	30.5
TOTAL HEIGHT	IN 23.5	27	34.5
	CM 59.7	68.6	87.6
BASIN HEIGHT	IN 9.75	9.75	15.25
	CM 24.8	24.8	38.8
WEIGHT	LB 178	181	214
	KG 80.9	82.3	97.3
NORMAL VENT	IN 1.25	1.25	1.25
EMERGENCY VENT	IN 2	2	2



FILE MH 15297
WHEN SPECIFIED

REV	DATE	DESCRIPTION	BY
1	6-08	REMOVED HIGH/LOW ALARM LEVELS	KNA

E & C A	
SCALE NONE	APPROVED BY
DATE 3-29-00	DESIGNED BY TAMP
MODELS DT10, 15, & 25ULD	
W/ WEATHERPROOF RUPTURE BASIN	
DATE 04122	DRAWING NUMBER