

TOP VIEW

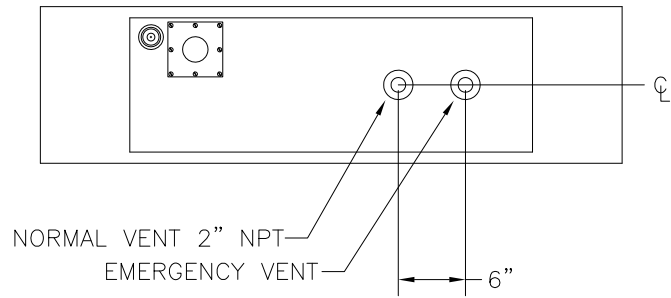

MODEL SLIM

		FT50	FT60	FT75	FT100	FT150	FT200
CAPACITY	GAL.	50	60	75	100	150	200
	LIT.	189	228	284	379	570	760
BASIN WIDTH	IN	52	52	52	64	101	134
	CM	132	132	132	162.6	256.5	340.4
BASIN DEPTH	IN	14	14	14	14	14	14
	CM	35.6	35.6	35.6	35.6	35.6	35.6
TANK WIDTH	IN	36	36	36	48	72	96
	CM	91.4	91.4	91.4	121.9	182.9	243.8
TANK DEPTH	IN	12	12	12	12	12	12
	CM	30.5	30.5	30.5	30.5	30.5	30.5
TOTAL HEIGHT	IN	38	42	50	50	50	50
	CM	96.5	106.7	127	127	127	127
BASIN HEIGHT	IN	27	32	39	41.75	40	40
	CM	68.6	81.3	99	106	101.6	101.6
WEIGHT	LB	266.9	300	336.6	432.7	701.8	907
	KG	121.3	136.4	153	196.7	319	412.3
NORMAL VENT	IN	2	2	2	2	2	2
EMERGENCY VENT	IN	2	2	3	3	3	4

FRONT VIEW

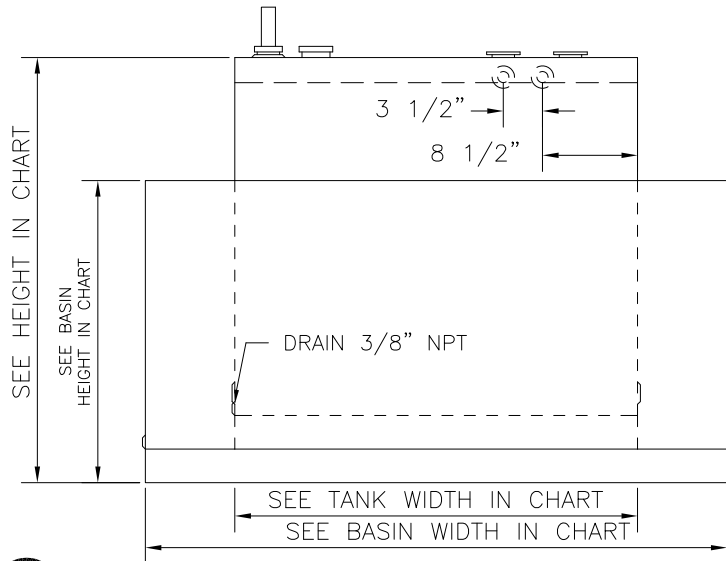

RIGHT SIDE VIEW

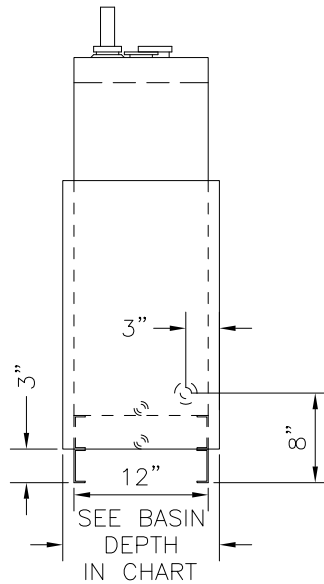

REAR VIEW

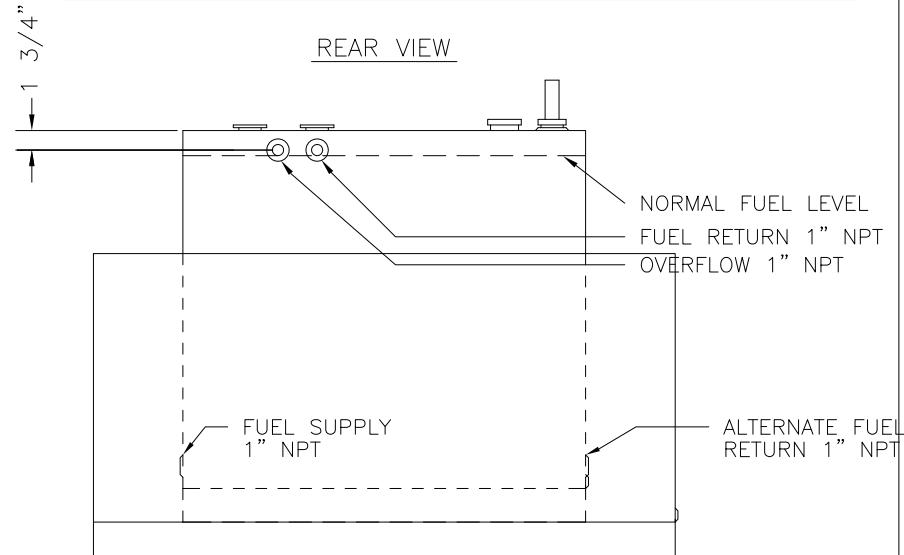

E & C A		
SCALE NONE	APPROVED BY	DRAWN BY TMP
DATE 7-1-99		REVISED
MODEL FT50,75,100,150,200 SLIM ULD		
ULTRA SLIM RUPTURE BASIN		DRAWING NUMBER 03818

REV	DATE	DESCRIPTION	BY
2	12-13	MOVED NORMAL VENT TO TOP	MEP
1	7-00	MOVED ALT RETURN TO DRAIN END	TMP