

MODEL SLIM

CAPACITY	GAL.	FT50	FT60	FT75	FT100	FT150	FT200
		LIT.	189	228	284	379	570
BASIN WIDTH	IN	48	48	48	60	84	108
	CM	121.9	121.9	121.9	152.4	213.4	274.3
BASIN DEPTH	IN	24	24	24	24	24	24
	CM	61	61	61	61	61	61
TANK WIDTH	IN	36	36	36	48	72	96
	CM	91.4	91.4	91.4	121.9	182.9	243.8
TANK DEPTH	IN	12	12	12	12	12	12
	CM	30.5	30.5	30.5	30.5	30.5	30.5
TOTAL HEIGHT	IN	38	42	50	50	50	50
	CM	96.5	106.7	127	127	127	127
BASIN HEIGHT	IN	18	21	25.5	27	29	30
	CM	45.7	53.3	63.8	67.5	72.5	75
WEIGHT	LB	303.9	300	373.6	469.7	738.8	944
	KG	136.8	136.4	168	212	332	425
NORMAL VENT	IN	2	2	2	2	2	2
EMERGENCY VENT	IN	2	2	3	3	3	4

TOP VIEW

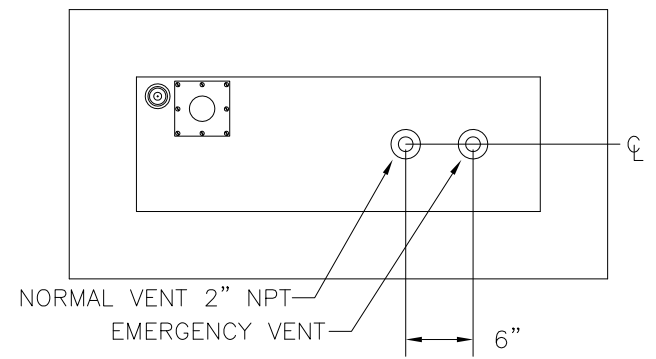

FRONT VIEW

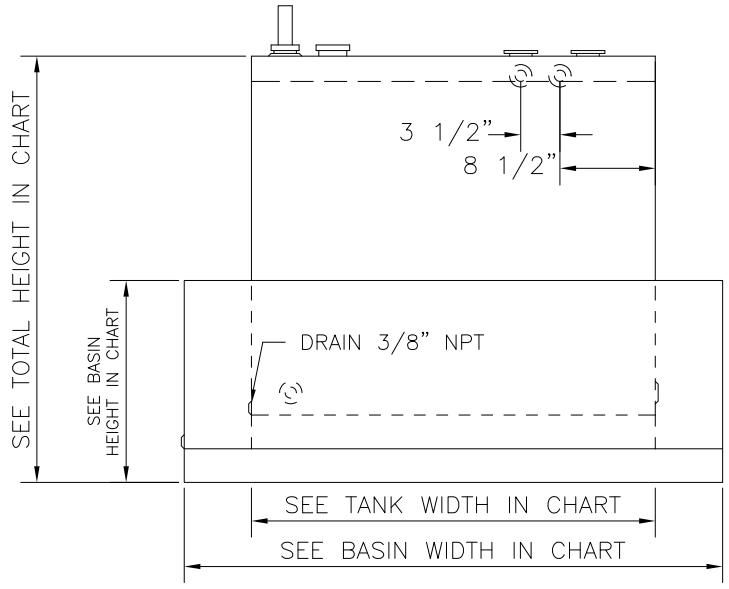

RIGHT SIDE VIEW

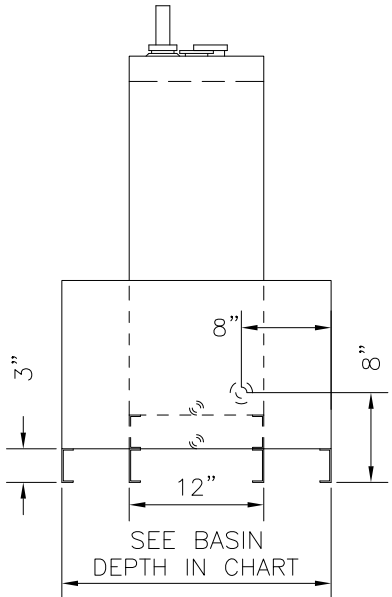

REAR VIEW

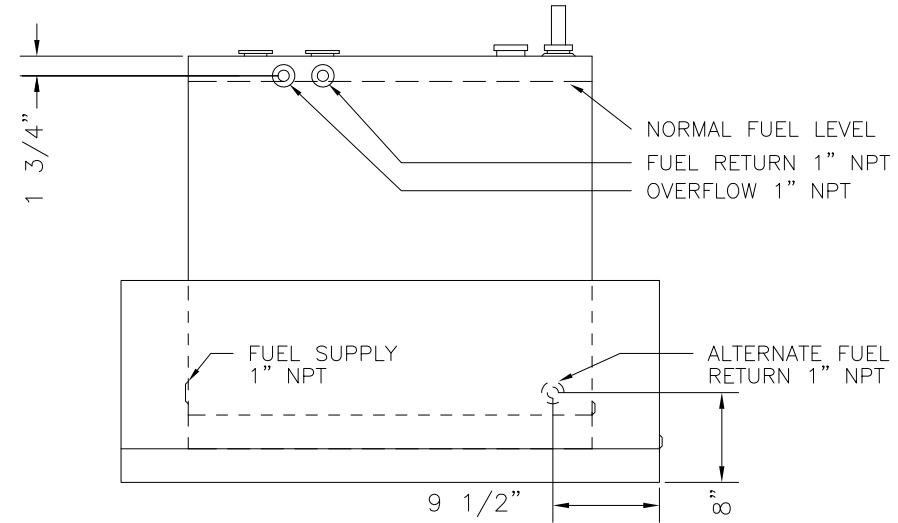

**UL LISTED**  
FILE MH 15297  
WHEN SPECIFIED

E & C A

SCALE NONE	APPROVED BY	DRAWN BY TMP
DATE 7-1-99		REVISED

MODEL FT50,60,75,100,150,200 SLIM

1	12-13	MOVED NORMAL VENT TO TOP	MEP
REV	DATE	DESCRIPTION	BY

WITH RUPTURE BASIN

DRAWING NUMBER  
03817