

		MODEL SLIM					
		DT50	DT60	DT75	DT100	DT150	DT200
CAPACITY	GAL.	50	60	75	100	150	200
	LIT.	189	228	284	379	570	760
BASIN WIDTH	IN	52	52	52	64	101	134
	CM	132	132	132	162.6	256.5	340.4
BASIN DEPTH	IN	14	14	14	14	14	14
	CM	35.6	35.6	35.6	35.6	35.6	35.6
TANK WIDTH	IN	36	36	36	48	72	96
	CM	91.4	91.4	91.4	121.9	182.9	243.8
TANK DEPTH	IN	12	12	12	12	12	12
	CM	30.5	30.5	30.5	30.5	30.5	30.5
TOTAL HEIGHT	IN	45	50	58	58	58	58
	CM	114.3	127	147.3	147.3	147.3	147.3
BASIN HEIGHT	IN	27	32	39	41.75	40	40
	CM	68.6	81.3	99	106	101.6	101.6
WEIGHT	LB	376	407	462	572	813	977
	KG	171	185	210	260	369.5	444
NORMAL VENT	IN	2	2	2	2	2	2
EMERGENCY VENT	IN	2	2	3	3	3	4

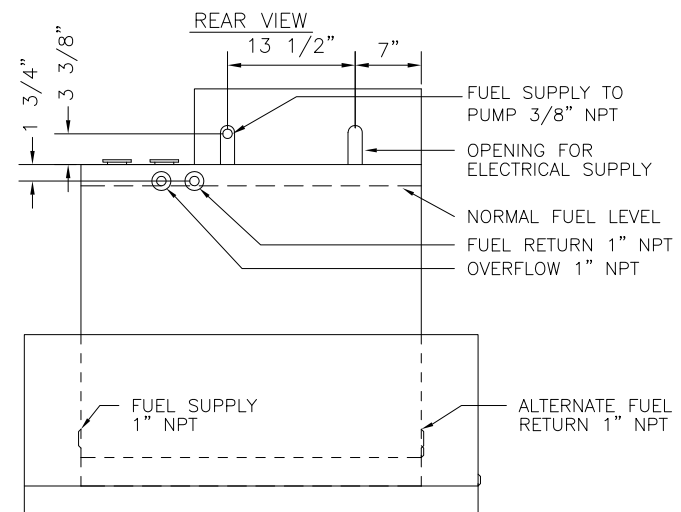
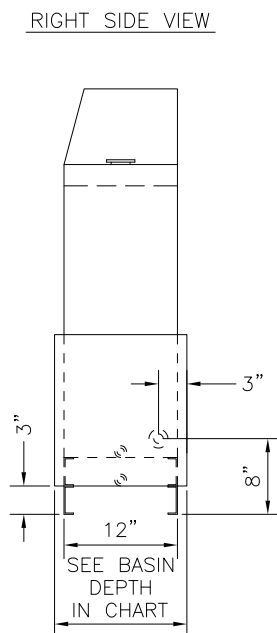
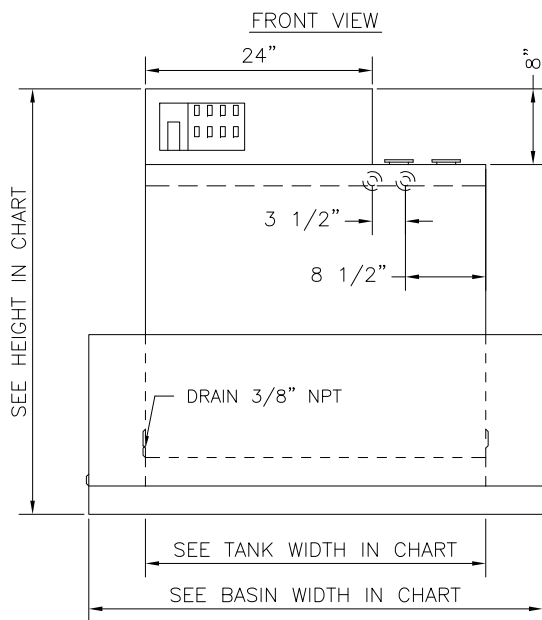

**UL LISTED**  
 FILE MH 15297  
 WHEN SPECIFIED

E & C A	
SCALE NONE	APPROVED BY
DATE 8-3-98	DRAWN BY: TMP
REVISED	
MODEL DT50,75,100,150,200 SLIM ULD	
ULTRA SLIM RUPTURE BASIN	
DRAWING NUMBER	03686

REV	DATE	DESCRIPTION	BY
4	12-13	MOVED NORMAL VENT TO TOP	MEP
3	6-08	REMOVED HIGH/LOW ALARM LEVELS	KNA
2	7-00	MOVED ALT RETURN TO DRAIN END	TMP
1	1-99	ADDED DIMENSIONS TO CHART	TMP