

FRONT VIEW

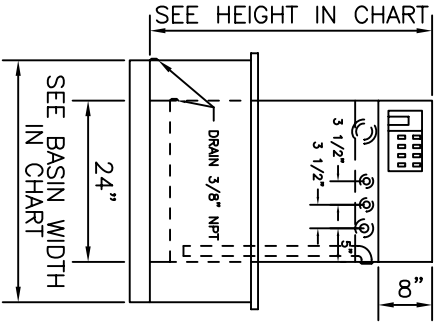

RIGHT SIDE VIEW

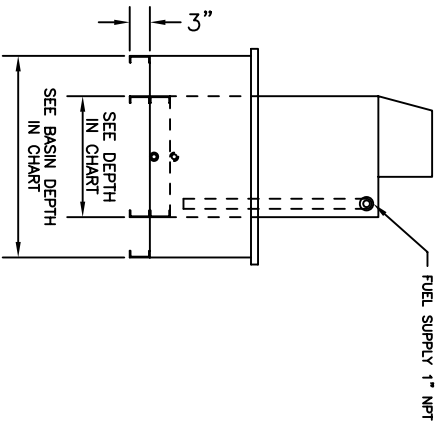

REAR VIEW

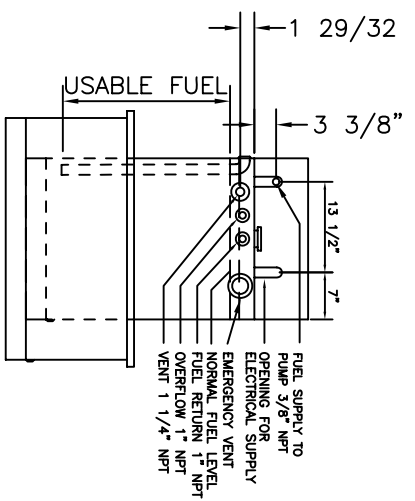

	MODEL			
	DT50	DT60	DT75	DT100
CAPACITY	GAL 50	60	75	100
	LIT 189	228	284	379
BASIN WIDTH	IN 36	36	36	36
	CM 91.4	91.4	91.4	91.4
BASIN DEPTH	IN 30	30	30	36
	CM 76.2	76.2	76.2	91.4
TANK WIDTH	IN 24	24	24	24
	CM 61	61	61	61
TANK DEPTH	IN 18	18	18	24
	CM 45.7	45.7	45.7	61
TOTAL HEIGHT	IN 45	50	58	58
	CM 114.3	127	147.3	147.3
BASIN HEIGHT	IN 19	22.25	27	29.75
	CM 48.3	54.5	68.6	75.6
WEIGHT	LB 306	330	370	425
	KG 139	150	168	193
EMERGENCY VENT	IN 2	2	2	3

E & C A

SCALE NONE

DATE 8-25-94

APPROVED BY RLL

DT50ULD, 60ULD, 75ULD, 100ULD

WITH WEATHER PROOF RUPTURE BASIN

DRAWING NUMBER 03496



FILE MH 15297  
WHEN SPECIFIED

REV	DATE	DESCRIPTION	BY
3	6-08	REMOVED HIGH/LOW ALARM LEVELS KVA	TMP
2	7-00	ADDED FUEL SUPPLY DIPTUBE	TMP
1	7-98	MOVED EMERGENCY VENT TO BACK	TMP