

		MODEL SLIM					
		DT50	DT60	DT75	DT100	DT150	DT200
CAPACITY	GAL.	50	60	75	100	150	200
	LIT.	189	228	284	379	570	760
BASIN WIDTH	IN	48	48	48	60	84	108
	CM	121.9	121.9	121.9	152.4	213.4	274.3
BASIN DEPTH	IN	24	24	24	24	24	24
	CM	61	61	61	61	61	61
TANK WIDTH	IN	36	36	36	48	72	96
	CM	91.4	91.4	91.4	121.9	182.9	243.8
TANK DEPTH	IN	12	12	12	12	12	12
	CM	30.5	30.5	30.5	30.5	30.5	30.5
TOTAL HEIGHT	IN	45	50	58	58	58	58
	CM	114.3	127	147.3	147.3	147.3	147.3
BASIN HEIGHT	IN	18	21	25.5	27	29	30
	CM	45.7	53.3	63.8	67.5	72.5	75
WEIGHT	LB	303.9	365	373.6	469.7	738.8	944
	KG	136.8	163	168	212	332	425
NORMAL VENT	IN	2	2	2	2	2	2
EMERGENCY VENT	IN	2	2	3	3	3	4

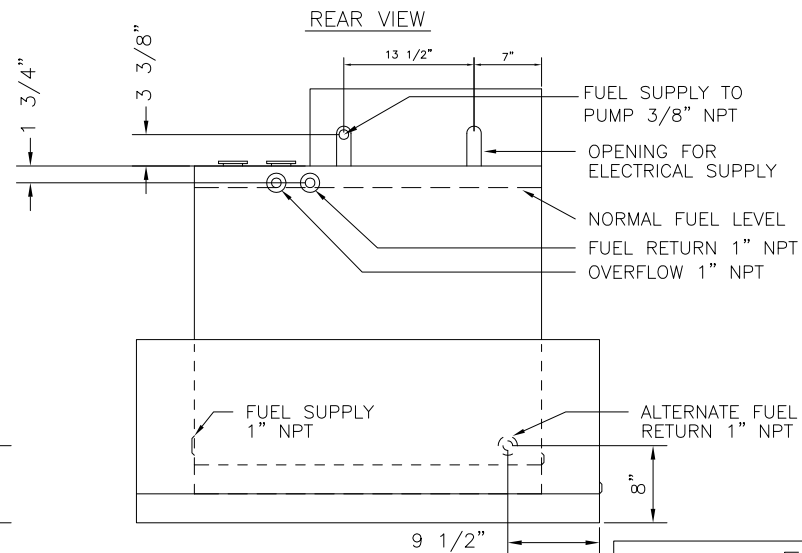
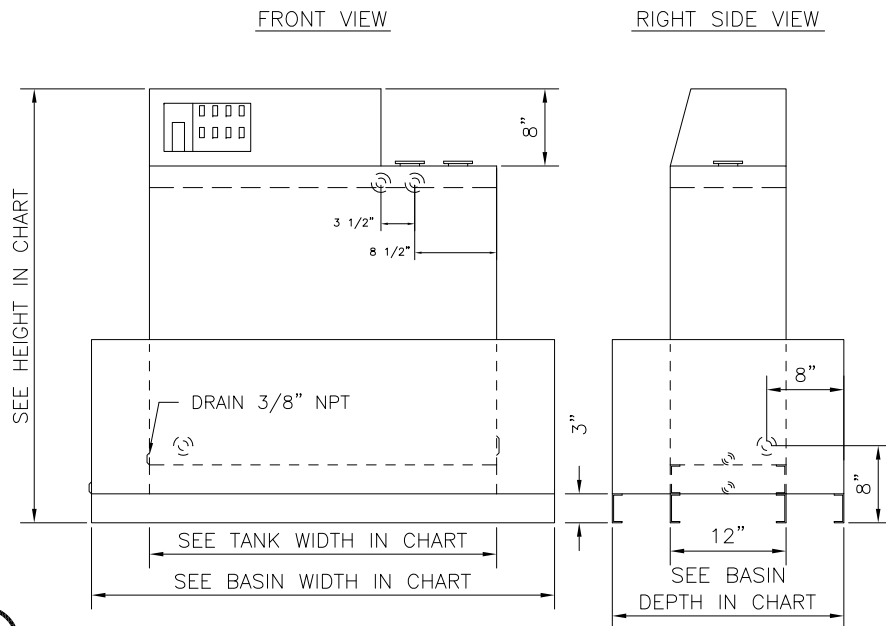

E & C A		
SCALE NONE	APPROVED BY	DRAWN BY: TMP
DATE 4-24-96		REVISED
MODEL DT50,60,75,100,150,200 SLIM		
WITH RUPTURE BASIN		DRAWING NUMBER 03102

REV	DATE	DESCRIPTION	BY
3	12-13	MOVED NORMAL VENT TO TOP	MEP
2	6-08	REMOVED HIGH/LOW ALARM LEVELS	KNA
1	2/01	ADDED 60 GALLON DIMENSIONS	WFP