

FRONT VIEW

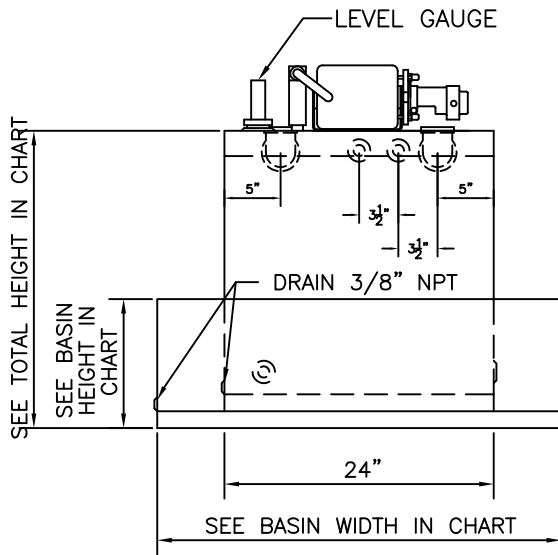

RIGHT SIDE VIEW

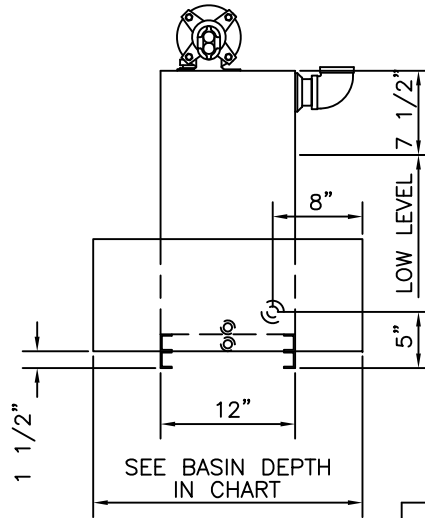

REAR VIEW

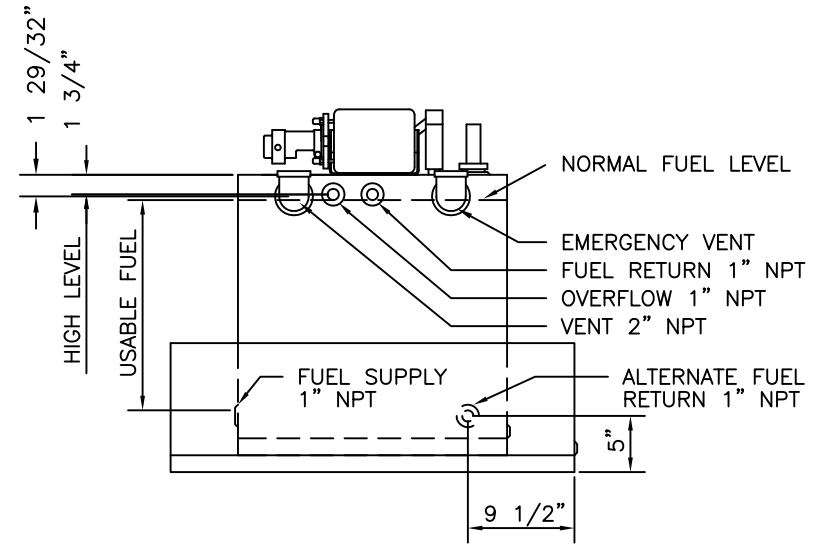

		MODEL			
		ET10	ET15	ET25	ET30
CAPACITY	GAL.	10	15	25	30
	LIT.	38	95	95	114
BASIN WIDTH	IN	32	32	32	32
	CM	81.3	81.3	81.3	81.3
BASIN DEPTH	IN	20	20	20	20
	CM	50.8	50.8	50.8	50.8
TANK WIDTH	IN	24	24	24	24
	CM	61	61	61	61
TANK DEPTH	IN	12	12	12	12
	CM	30.5	30.5	30.5	30.5
TOTAL HEIGHT	IN	15.5	19	26.5	29
	CM	39.4	48.3	67.3	73.7
BASIN HEIGHT	IN	9.75	9.75	15.25	17.75
	CM	24.8	24.8	38.8	45.1
WEIGHT	LB	146	155	193	218
	KG	66.4	70.5	87.7	99.1
EMERGENCY VENT	IN	2	2	2	2

E & C A			
SCALE NONE	APPROVED BY	DRAWN BY: TMP	
DATE 5-18-95		REVISED	
MODEL ET10, 15, 25, 30ULD			
w/ RUPTURE BASIN			DRAWING NUMBER 02842

REV	DATE	DESCRIPTION	BY
4	6-13	CHANGED VENT TO 2" NPT	JS
3	4-04	ADDED 30 GALLON TANK	TMP
2	4-04	CHANGED WEIGHTS	TMP
1	8-98	CHANGED BASIN SIZE	TMP

