

TOP VIEW

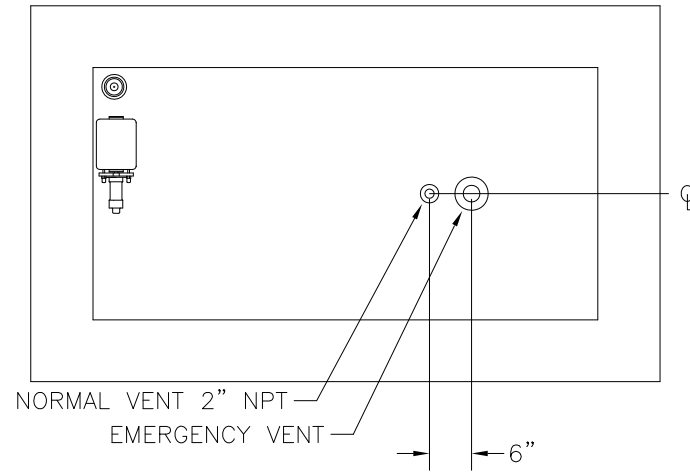

MODEL

CAPACITY	GAL. LIT.	ET400	ET450	ET500	ET550	ET600
		1514	1703	1893	2082	2271
BASIN WIDTH	IN	54	54	54	54	54
	CM	136.6	136.6	136.6	136.6	136.6
BASIN DEPTH	IN	75	83	90	97	104
	CM	189.8	210	227.7	245.5	263.1
TANK WIDTH	IN	36	36	36	36	36
	CM	91.4	91.4	91.4	91.4	91.4
TANK DEPTH	IN	57	65	72	79	86
	CM	144.8	165	182.9	200.6	218.4
TOTAL HEIGHT	IN	54.5	54.5	54.5	54.5	54.5
	CM	138.4	138.4	138.4	138.4	138.4
BASIN HEIGHT	IN	39	39	39	39	39
	CM	98.7	98.7	98.7	98.7	98.7
WEIGHT	LB	1006	1093	1171	1394	1482
	KG	457	497	532	634	674
EMERGENCY VENT	IN	4	4	4	4	5

FRONT VIEW

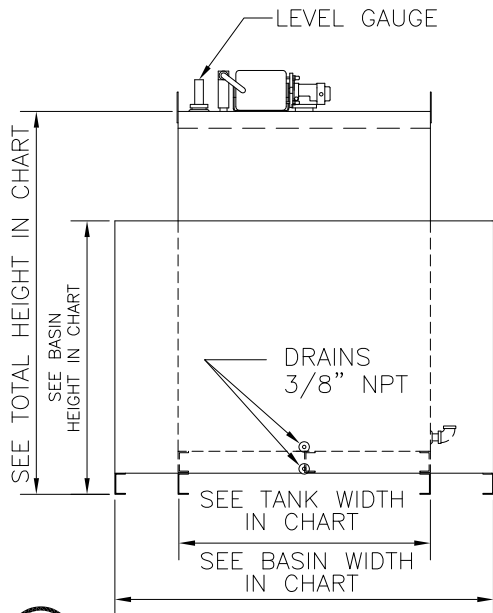

RIGHT SIDE VIEW

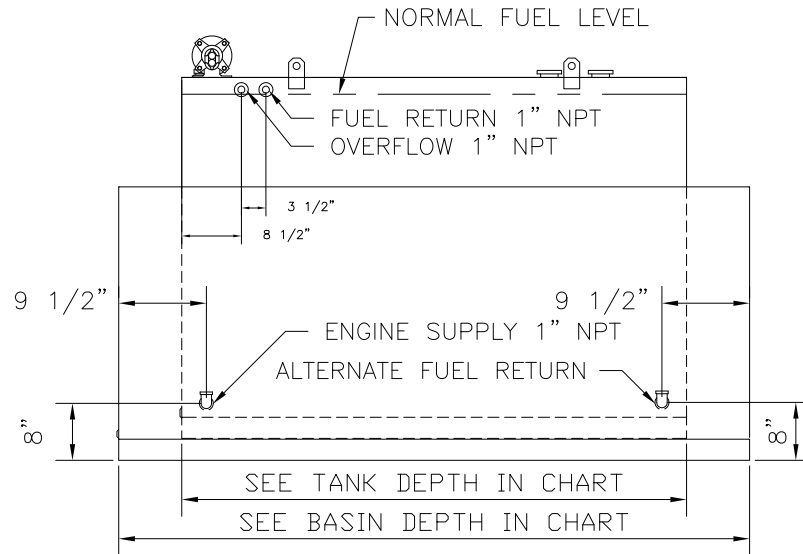

REAR VIEW

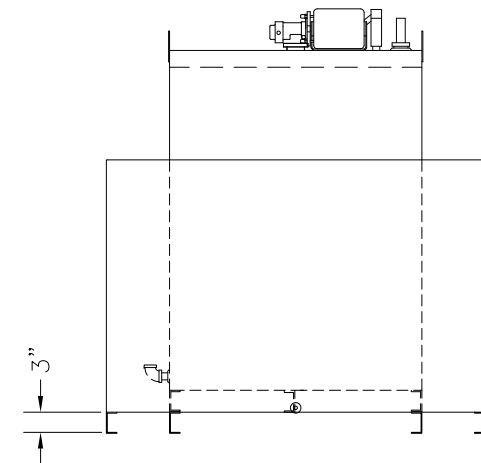

1	12-13	MOVED NORMAL VENT TO TOP	MEP
REV	DATE	DESCRIPTION	BY

E & C A		
SCALE NONE	APPROVED BY	DRAWN BY: TMP
DATE 5-18-95		REVISED
ET400, 450, 500, 550, 600ULD		
w/ RUPTURE BASIN		DRAWING NUMBER 02836