

FRONT VIEW

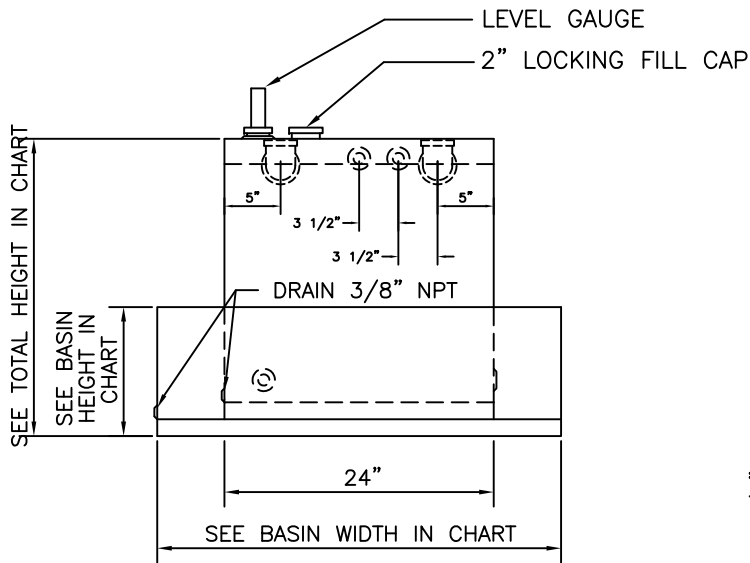

RIGHT SIDE VIEW

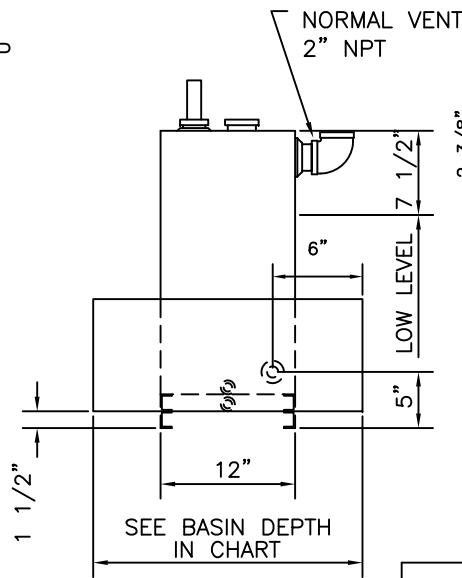

REAR VIEW

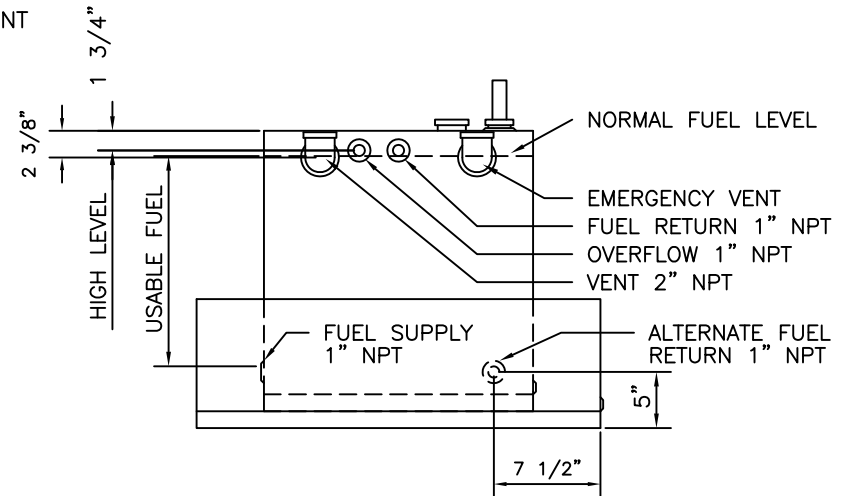

		MODEL			
		FT10	FT15	FT25	FT30

CAPACITY	GAL.	10	15	25	30
	LIT.	38	95	95	114
BASIN WIDTH	IN	32	32	32	32
	CM	81.3	81.3	81.3	81.3
BASIN DEPTH	IN	20	20	20	20
	CM	50.8	50.8	50.8	50.8
TANK WIDTH	IN	24	24	24	24
	CM	61	61	61	61
TANK DEPTH	IN	12	12	12	12
	CM	30.5	30.5	30.5	30.5
TOTAL HEIGHT	IN	15.5	19	26.5	29
	CM	39.4	48.3	67.3	73.7
BASIN HEIGHT	IN	9.75	9.75	15.25	17.75
	CM	24.8	24.8	38.8	45.1
WEIGHT	LB	128	137	175	201
	KG	58.2	62.3	79.5	91.4
EMERGENCY VENT	IN	2	2	2	2

UL LISTED
 FILE MH 15297
 WHEN SPECIFIED

E & C A		
SCALE NONE	APPROVED BY	DRAWN BY: TMP
DATE 12-16-94		REVISED
MODEL FT10, 15, 25, 30ULD		
w/ RUPTURE BASIN		DRAWING NUMBER 02717

REV	DATE	DESCRIPTION	BY
4	7-12	CHANGED VENT TO 2" NPT	MEP
3	4-04	ADDED 30 GALLON TANK	TMP
2	4-04	CORRECTED WEIGHTS	TMP
1	8-98	CHANGED BASIN SIZE	TMP