

TOP VIEW

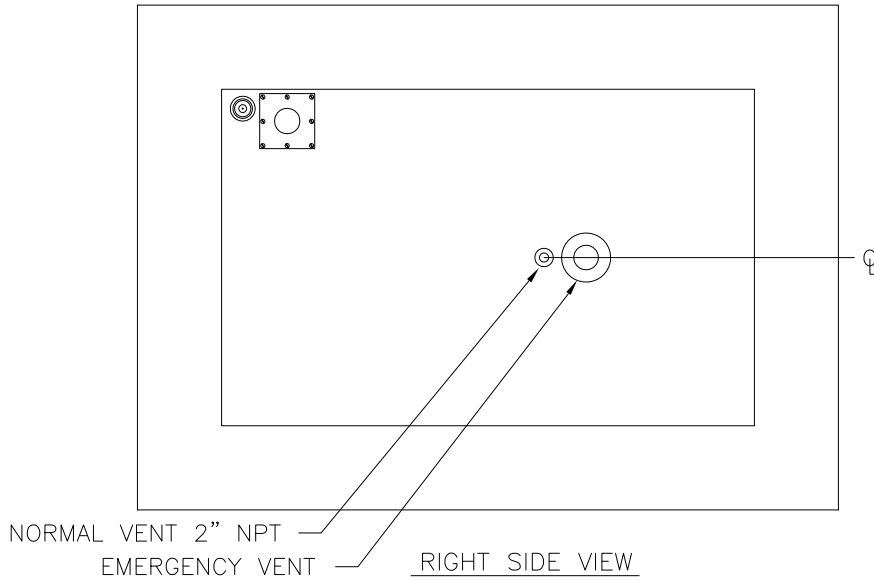

		MODEL			
		FT700	FT800	FT900	FT1000
CAPACITY	GAL	700	800	900	1000
	LIT	2660	3040	3420	3800
BASIN WIDTH	IN	72	72	72	72
	CM	183	183	183	183
BASIN DEPTH	IN	100	110	121	132
	CM	254	279.4	307	335
TANK WIDTH	IN	48	48	48	48
	CM	121.9	121.9	121.9	121.9
TANK DEPTH	IN	76	86	97	108
	CM	193	218.4	246.4	274.3
TOTAL HEIGHT	IN	54.5	54.5	54.5	54.5
	CM	139	139	139	139
BASIN HEIGHT	IN	36.75	38	39	39.5
	CM	93.3	96.5	99	100.3
WEIGHT	LB	1490	1642	1807	1966
	KG	677	746	821	894
EMERGENCY VENT	IN	6	6	6	6

FRONT VIEW

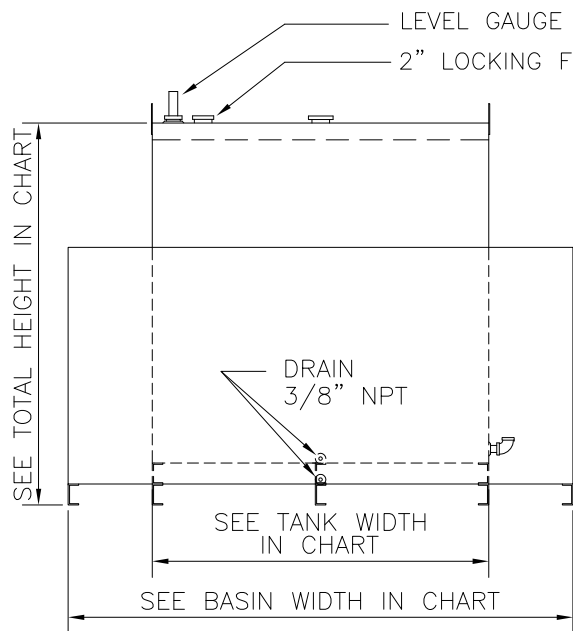

RIGHT SIDE VIEW

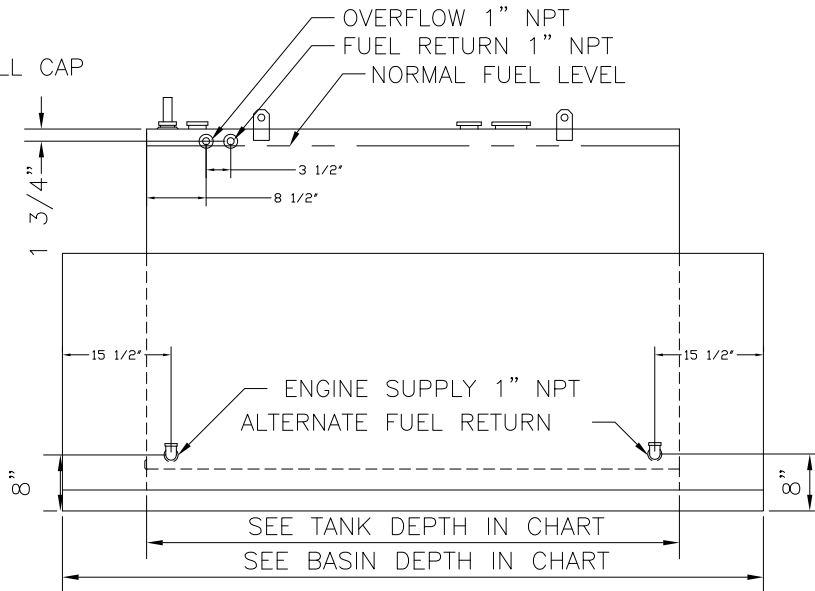

REAR VIEW

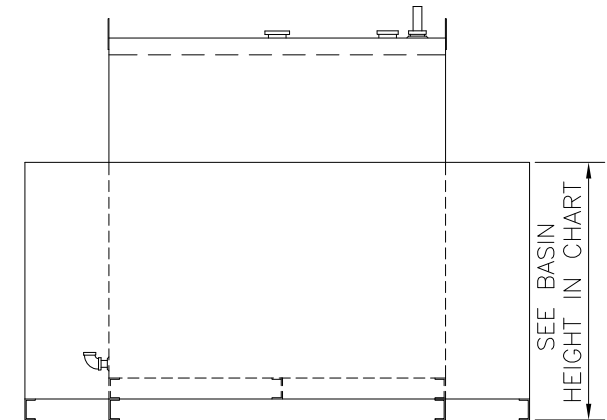

UL LISTED
FILE MH 15297
WHEN SPECIFIED

REV	DATE	DESCRIPTION	BY
2	12-13	MOVED NORMAL VENT TO TOP	MEP
1	10-97	CORRECTED ERRORS	TMP

E & C A		
SCALE NONE	APPROVED BY	DRAWN BY: TMP
DATE 11-23-94		REVISED
FT700UL, 800ULD, 900ULD, 1000ULD		
WITH RUPTURE BASIN		DRAWING NUMBER 02674