

TOP VIEW

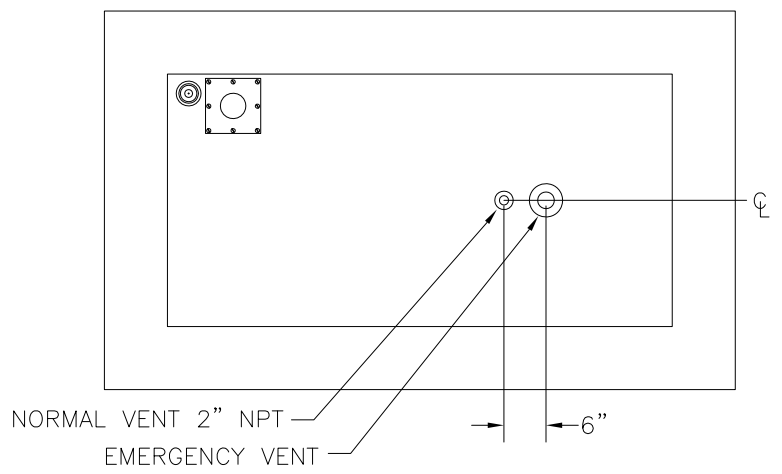

MODEL

CAPACITY	GAL.	FT400	FT450	FT500	FT550	FT600
		LIT.	1514	1703	1893	2082
BASIN WIDTH	IN	54	54	54	54	54
	CM	136.6	136.6	136.6	136.6	136.6
BASIN DEPTH	IN	75	83	90	97	104
	CM	189.8	210	227.7	245.5	263.1
TANK WIDTH	IN	36	36	36	36	36
	CM	91.4	91.4	91.4	91.4	91.4
TANK DEPTH	IN	57	65	72	79	86
	CM	144.8	165	182.9	200.6	218.4
TOTAL HEIGHT	IN	54.5	54.5	54.5	54.5	54.5
	CM	138.4	138.4	138.4	138.4	138.4
BASIN HEIGHT	IN	39	39	39	39	39
	CM	98.7	98.7	98.7	98.7	98.7
WEIGHT	LB	986	1073	1151	1374	1462
	KG	448	488	523	625	665
EMERGENCY VENT	IN	4	4	4	4	5

FRONT VIEW

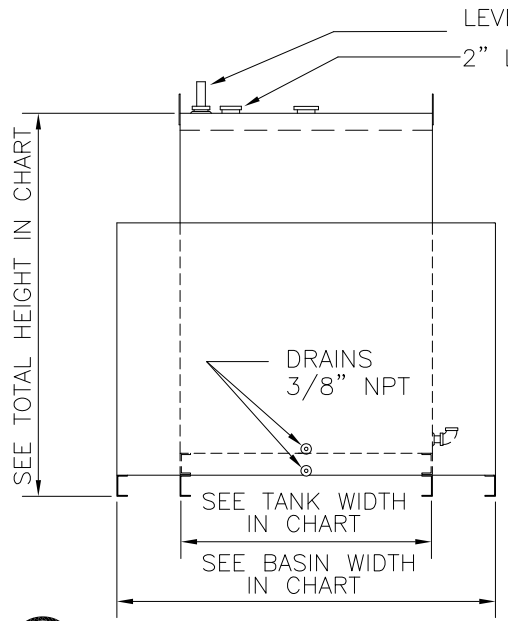

RIGHT SIDE VIEW

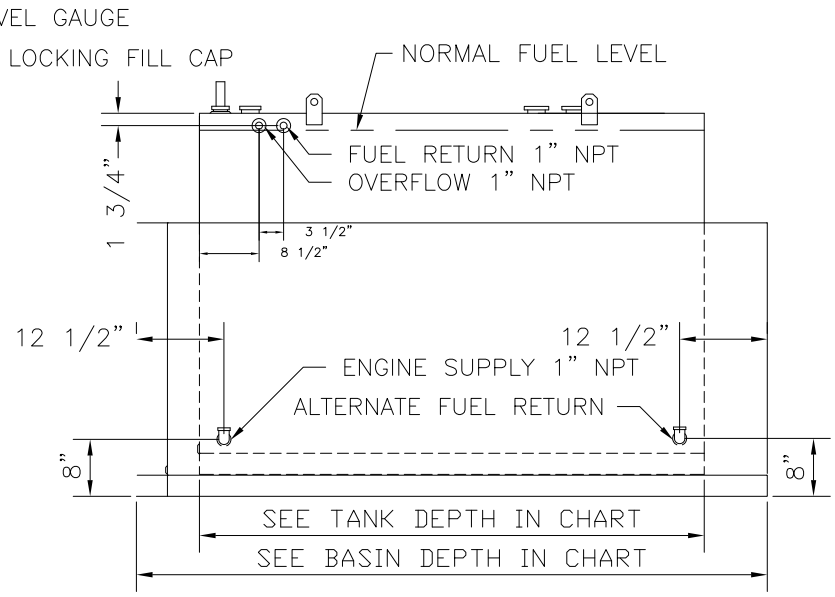

REAR VIEW

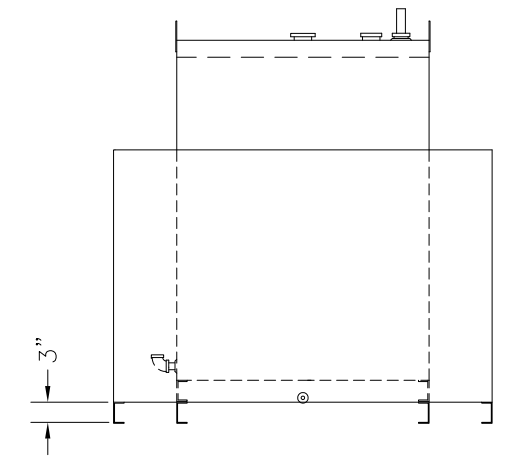

E & C A		
SCALE NONE	APPROVED BY	DRAWN BY: TMP
DATE 12-19-94		REVISED
FT400, 450, 500, 550, 600ULD		
w/ RUPTURE BASIN		DRAWING NUMBER 02673

REV	DATE	DESCRIPTION	MEP BY
1	12-13	MOVED NORMAL VENT TO TOP	MEP