

		MODEL			
		FT700	FT800	FT900	FT1000
CAPACITY	GAL.	700	800	900	1000
	LIT.	2660	3040	3420	3800
WIDTH	IN	48	48	48	48
	CM	121.9	121.9	121.9	121.9
DEPTH	IN	76	86	97	108
	CM	193	218.4	246.4	274.3
HEIGHT	IN	51.5	51.5	51.5	51.5
	CM	130.8	130.8	130.8	130.8
WEIGHT	LB	782	864	955	1045
	KG	356	393	434	475
EMERGENCY VENT	IN	5	5	5	5

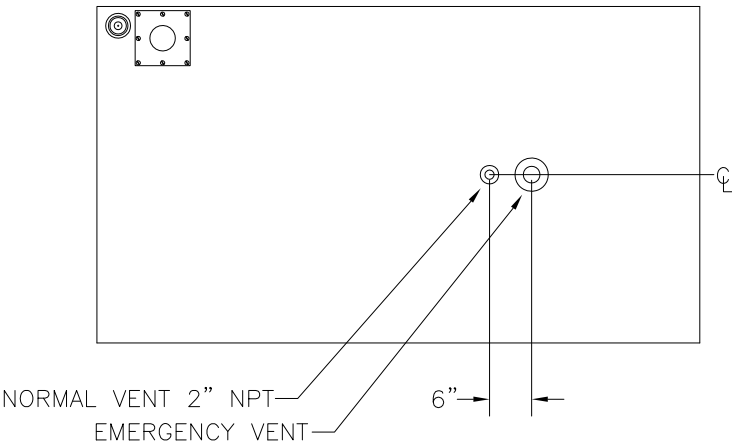

FRONT VIEW

RIGHT SIDE VIEW

REAR VIEW

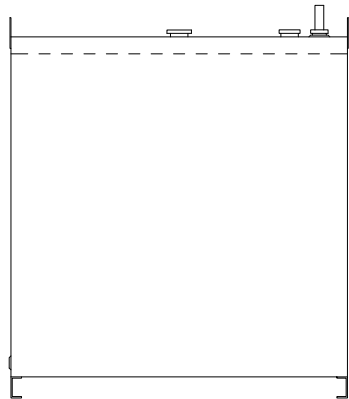
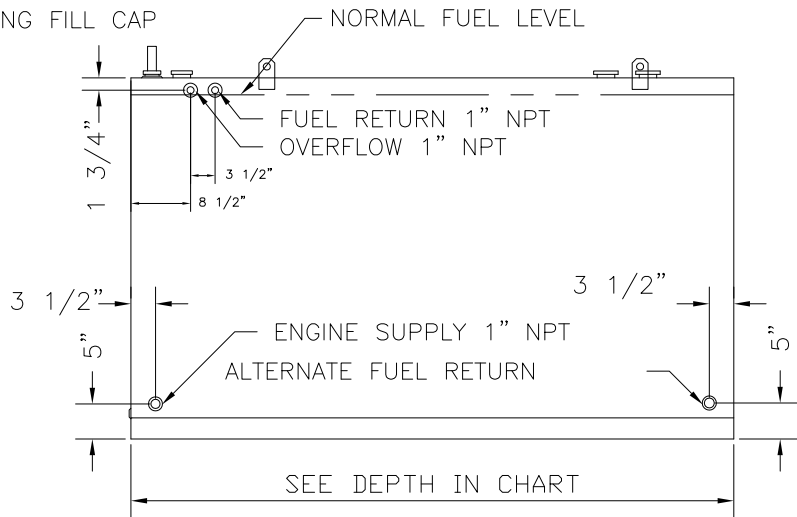
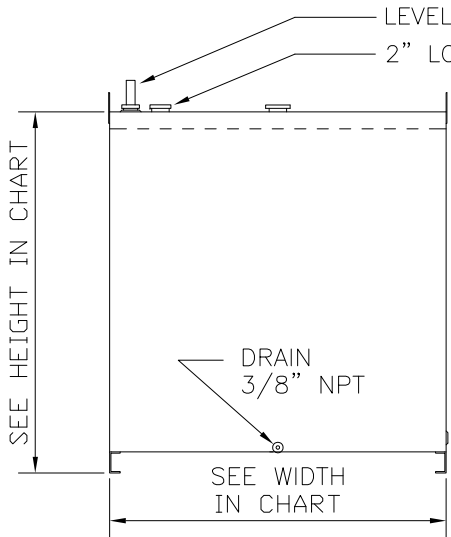

FILE MH 15297
WHEN SPECIFIED

REV	DATE	DESCRIPTION	MEP BY
1	12-13	MOVED NORMAL VENT TO TOP	MEP

E & C A		
SCALE NONE	APPROVED BY	DRAWN BY: TMP
DATE 12-19-94		REVISED
FT700, 800, 900, 1000ULD		
UL DESIGNED TANKS		DRAWING NUMBER 02672