

		MODEL					
		DT150	DT200	DT275	DT300	DT325	DT350

CAPACITY	GAL	150	200	275	300	325	350
	LIT	570	758	1041	1136	1230	1325
BASIN WIDTH	IN	36	36	36	36	40	36
	CM	91.5	91.5	91.5	91.5	101.6	91.5
BASIN DEPTH	IN	48	60	72	77	72	87
	CM	121.9	152.4	182.9	195.6	182.9	221
TANK WIDTH	IN	24	24	24	24	28	24
	CM	61	61	61	61	71.1	61
TANK DEPTH	IN	36	48	60	65	60	75
	CM	91.4	121.9	152.4	165	152.4	190.5
TOTAL HEIGHT	IN	58	62.5	62.5	62.5	62.5	62.5
	CM	147.3	158.7	158.1	158.1	158.1	158.1
BASIN HEIGHT	IN	33	35	40	40.5	42	42
	CM	83.9	88.9	101.6	102.9	106.7	106.7
WEIGHT	LB	588	716	902	953	959	1093
	KG	267	324	410	433	435	497
EMERGENCY VENT	IN	3	3	4	4	4	4

TOP VIEW

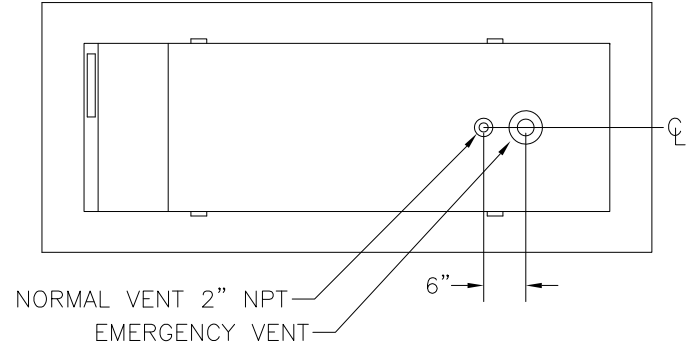

FRONT VIEW

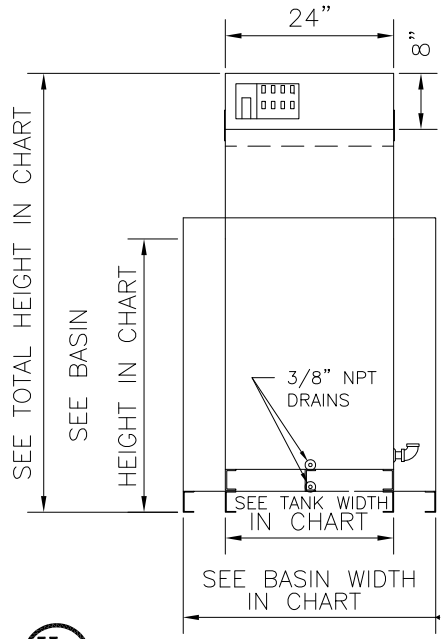

RIGHT SIDE VIEW

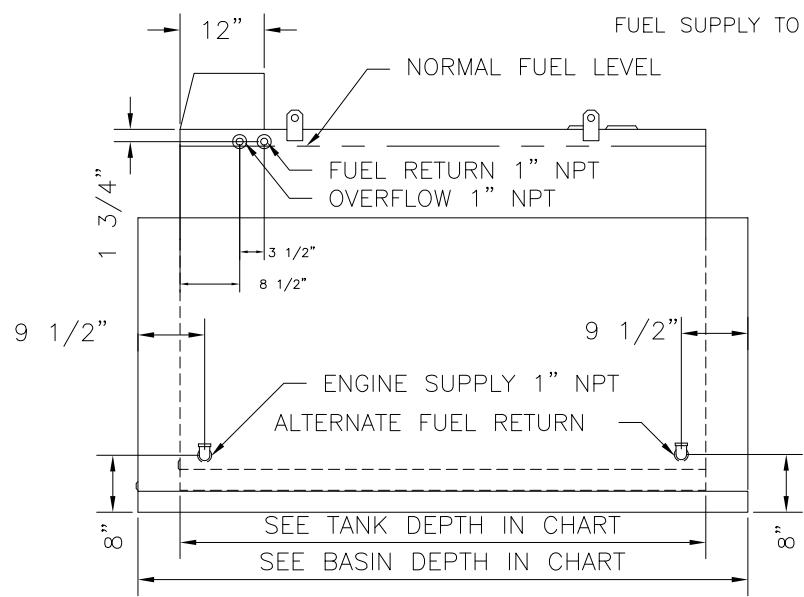

REAR VIEW

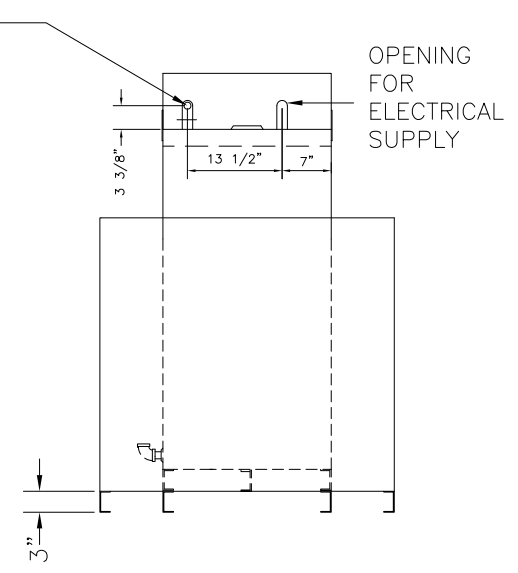

**UL LISTED**  
FILE MH 15297  
WHEN SPECIFIED

E & C A		
SCALE NONE	APPROVED BY	DRAWN BY: TMP
DATE 1-12-87		REVISED
DT150,200,275,300,325,350ULD		
w/ RUPTURE BASIN		DRAWING NUMBER 02667

REV	DATE	DESCRIPTION	BY
2	7-12	MOVED NORMAL VENT TO TOP	MEP
1	6-08	REMOVED HIGH/LOW ALARM LEVELS	KNA