

FRONT VIEW

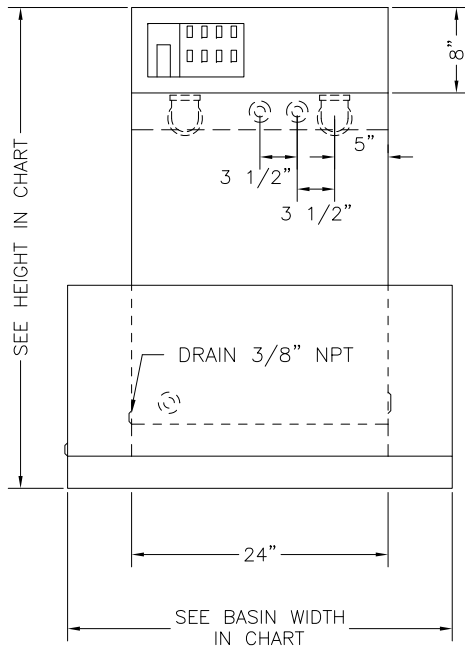

RIGHT SIDE VIEW

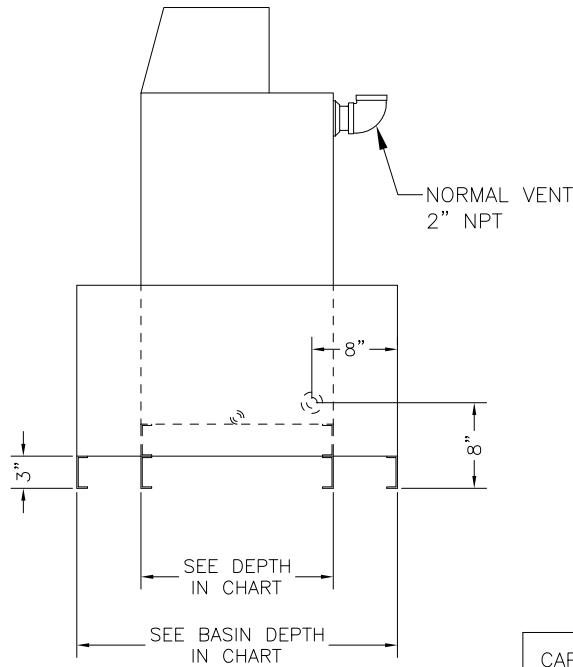

REAR VIEW

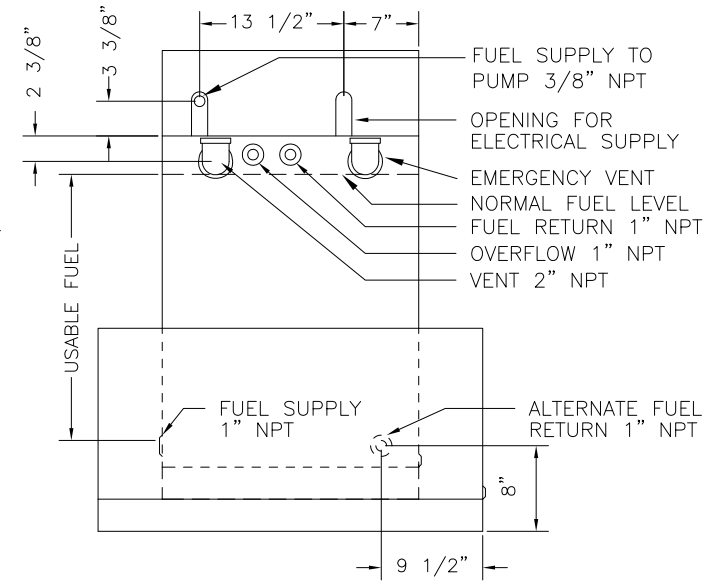

		MODEL			
		DT50	DT60	DT75	DT100
CAPACITY	GAL	50	60	75	100
	LIT	189	228	284	379
BASIN WIDTH	IN	36	36	36	36
	CM	91.4	91.4	91.4	91.4
BASIN DEPTH	IN	30	30	30	36
	CM	76.2	76.2	76.2	91.4
TANK WIDTH	IN	24	24	24	24
	CM	61	61	61	61
TANK DEPTH	IN	18	18	18	24
	CM	45.7	45.7	45.7	61
TOTAL HEIGHT	IN	45	50	58	58
	CM	114.3	127	147.3	147.3
BASIN HEIGHT	IN	19	22.25	27	29.75
	CM	48.3	54.5	68.6	75.6
WEIGHT	LB	306	330	370	425
	KG	139	150	168	193
EMERGENCY VENT	IN	2	2	2	3



E & C A		
SCALE NONE	APPROVED BY	DRAWN BY RLL
DATE 8-25-94		REVISED
DT50ULD, 60ULD, 75ULD, 100ULD		
WITH RUPTURE BASIN		DRAWING NUMBER 02666

REV	DATE	DESCRIPTION	BY
3	7-12	CHANGED VENT TO 2" NPT	MEP
2	6-08	REMOVED HIGH/LOW ALARM LEVELS	KNA
1	7-98	MOVED EMERGENCY VENT TO BACK	TMP