

TOP VIEW

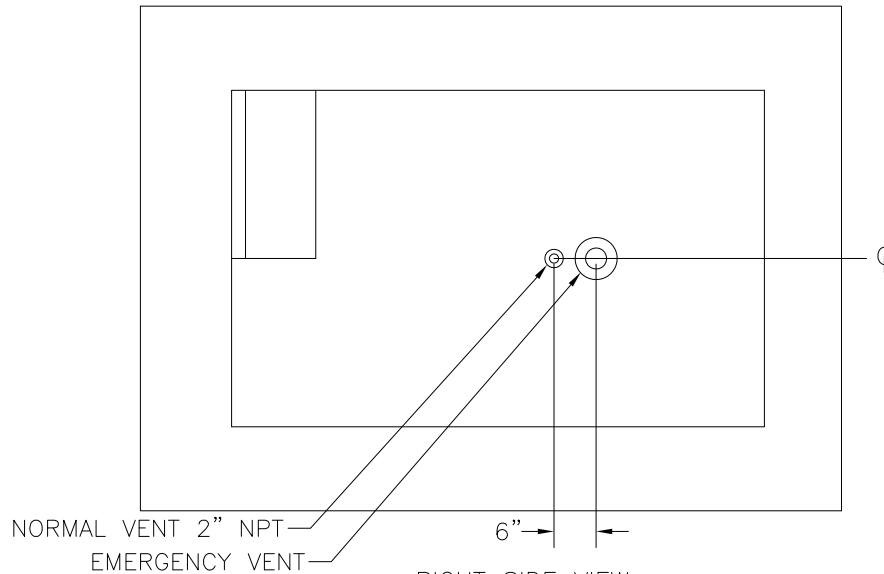

RIGHT SIDE VIEW

MODEL

		DT700	DT800	DT900	DT1000
CAPACITY	GAL	700	800	900	1000
	LIT	2660	3040	3420	3800
BASIN WIDTH	IN	72	72	72	72
	CM	183	183	183	183
BASIN DEPTH	IN	100	110	121	132
	CM	254	279.4	307	335
TANK WIDTH	IN	48	48	48	48
	CM	121.9	121.9	121.9	121.9
TANK DEPTH	IN	76	86	97	108
	CM	193	218.4	246.4	274.3
TOTAL HEIGHT	IN	62.5	62.5	62.5	62.5
	CM	159	159	159	159
BASIN HEIGHT	IN	36.75	38	39	39.5
	CM	93.3	96.5	99	100.3
WEIGHT	LB	1556	1708	1873	2032
	KG	707	776	851	1016
EMERGENCY VENT	IN	5	5	5	5

REAR VIEW

FRONT VIEW

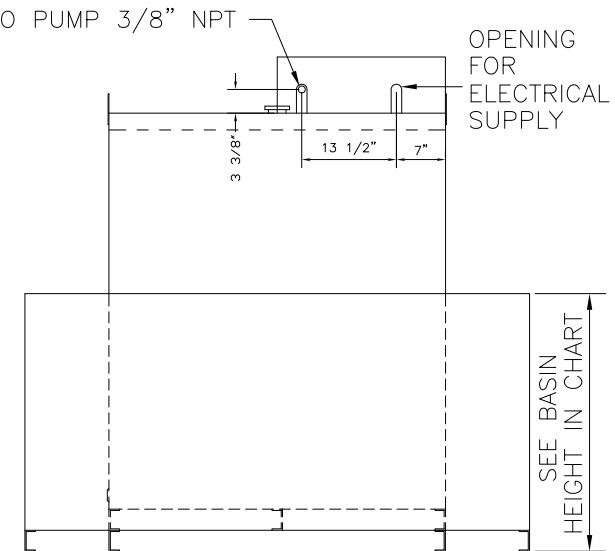
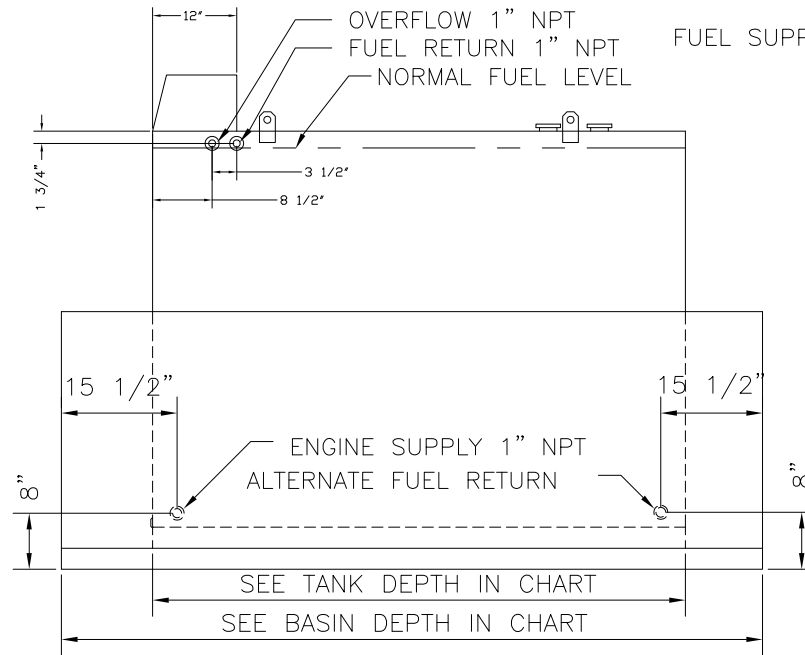
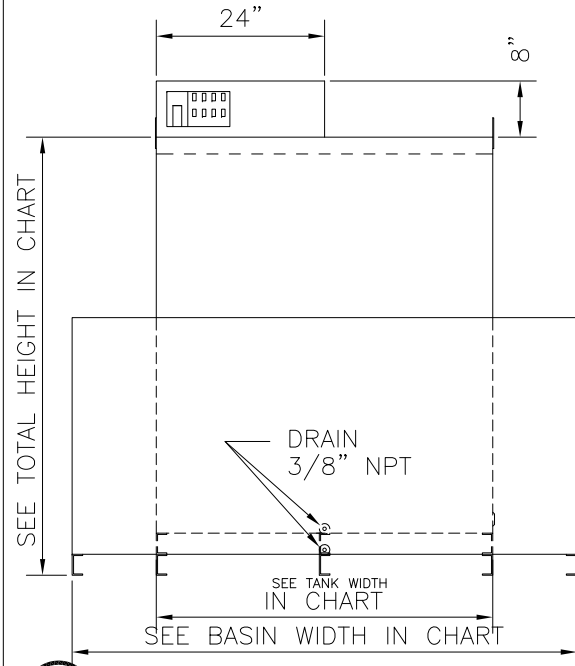

**UL LISTED**  
FILE MH 15297  
WHEN SPECIFIED

E & C A		
SCALE NONE	APPROVED BY	DRAWN BY: TMP
DATE 8-24-92		REVISED
DT700UL, 800ULD, 900ULD, 1000ULD		
WITH RUPTURE BASIN		DRAWING NUMBER 02665

1	12-13	MOVED NORMAL VENT TO TOP	MEP
REV	DATE	DESCRIPTION	BY