

		MODEL					
		FT150	FT200	FT275	FT300	FT325	FT350
CAPACITY	GAL	150	200	275	300	325	350
	LIT	570	758	1041	1136	1230	1325
BASIN WIDTH	IN	36	36	36	36	40	36
	CM	91.5	91.5	91.5	91.5	101.6	91.5
BASIN DEPTH	IN	48	60	72	77	72	87
	CM	121.9	152.4	182.9	195.6	182.9	221
TANK WIDTH	IN	24	24	24	24	28	24
	CM	61	61	61	61	71.1	61
TANK DEPTH	IN	36	48	60	65	60	75
	CM	91.4	121.9	152.4	165	152.4	190.5
TOTAL HEIGHT	IN	50	54.5	54.5	54.5	54.5	54.5
	CM	127	138	138	138	138	138
BASIN HEIGHT	IN	33	35	40	40.5	42	42
	CM	83.9	88.9	101.6	102.9	106.7	106.7
WEIGHT	LB	526	645	840	891	897	1031
	KG	239	296	382	405	407	469
EMERGENCY VENT	IN	3	3	4	4	4	4

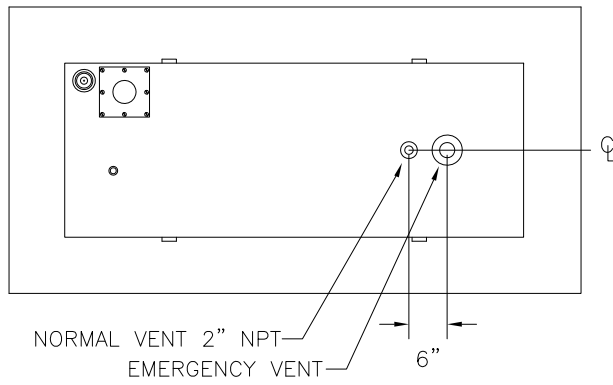

FRONT VIEW

RIGHT SIDE VIEW

REAR VIEW

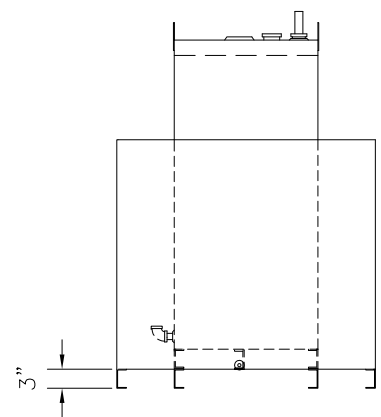
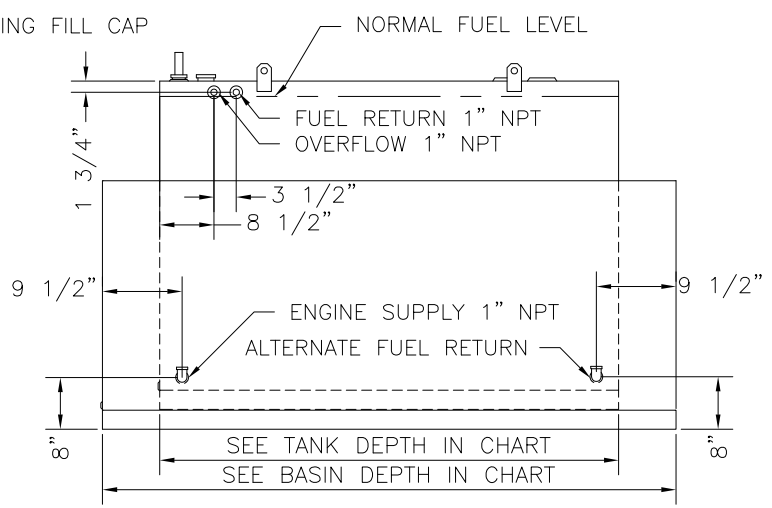
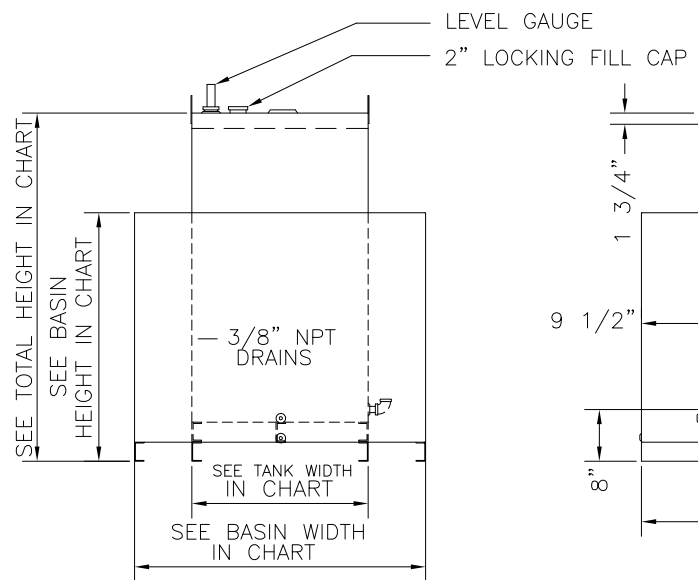

REV	DATE	DESCRIPTION	BY
1	7-12	MOVED NORMAL VENT TO TOP	MEP

E & C A

SCALE NONE	APPROVED BY	DRAWN BY: TMP
DATE 1-12-87		REVISED
FT150,200,275,300,325,350ULD		
w/ RUPTURE BASIN		DRAWING NUMBER 02657