

FRONT VIEW

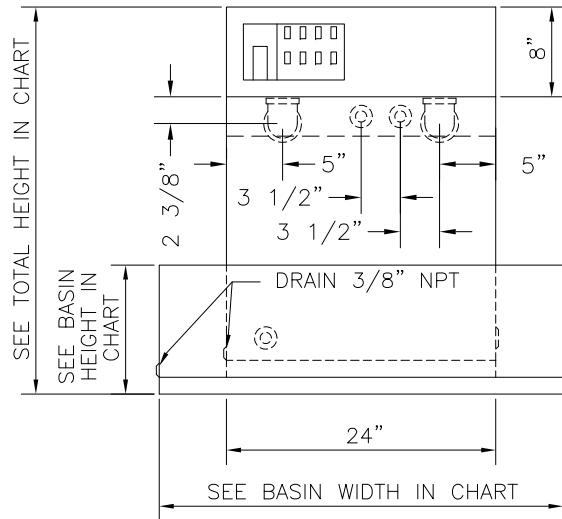

RIGHT SIDE VIEW

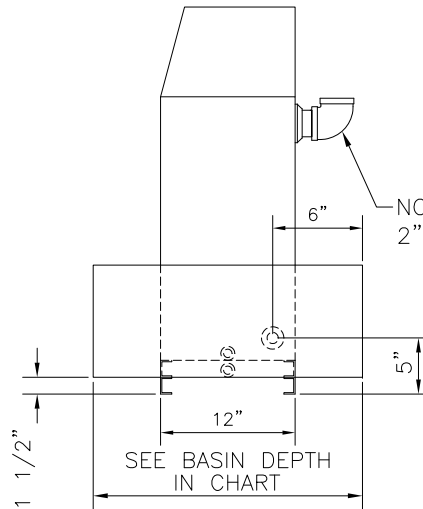

REAR VIEW

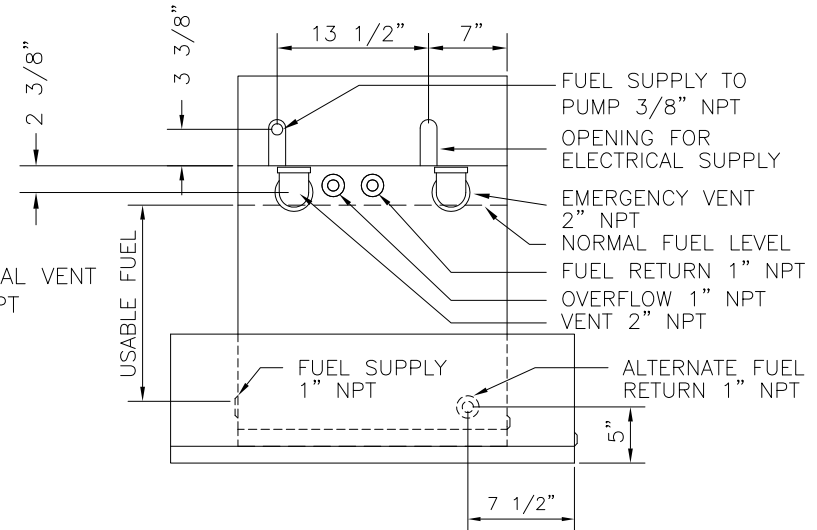

		MODEL			
		DT10	DT15	DT25	DT30
CAPACITY	GAL.	10	15	25	30
	LIT.	38	57	95	114
BASIN WIDTH	IN	32	32	32	32
	CM	81.3	81.3	81.3	81.3
BASIN DEPTH	IN	20	20	20	20
	CM	50.4	50.4	50.4	50.4
TANK WIDTH	IN	24	24	24	24
	CM	61	61	61	61
TANK DEPTH	IN	12	12	12	12
	CM	30.5	30.5	30.5	30.5
TOTAL HEIGHT	IN	23.5	27	34.5	37
	CM	59.7	68.6	87.6	94
BASIN HEIGHT	IN	9.75	9.75	15.25	17.75
	CM	24.8	24.8	38.8	45.1
WEIGHT	LB	190	199	237	262
	KG	86.4	90.5	107.7	119.1
NORMAL VENT	IN	2	2	2	2
EMERGENCY VENT	IN	2	2	2	2

				E & C A		
5	7-12	CHANGED VENT TO 2" NPT	MEP	SCALE NONE	APPROVED BY	DRAWN BY: TMP
4	6-08	REMOVED HIGH/LOW ALARM LEVELS	KNA	DATE 4-28-94		REVISED
3	4-04	ADDED 30 GALLON TANK	TMP	MODELS DT10, 15, 25, 30ULD		
2	4-04	CORRECTED WEIGHTS	TMP	w/ RUPTURE BASIN		
1	8-98	CHANGED BASIN SIZE	TMP	DRAWING NUMBER 02613		
REV	DATE	DESCRIPTION	BY			

