

		MODEL					
		FT150	FT200	FT275	FT300	FT325	FT350

CAPACITY	GAL.	150	200	275	300	325	350
	LIT.	570	758	1041	1136	1230	1325
WIDTH	IN	24	24	24	24	28	24
	CM	61	61	61	61	71.1	61
DEPTH	IN	36	48	60	65	60	76
	CM	91.4	121.9	152.4	165	152.4	190.5
HEIGHT	IN	47	51.5	51.5	51.5	51.5	51.5
	CM	119.4	130.8	130.8	130.8	130.8	130.8
WEIGHT	LB	300	401	484	498	530	565
	KG	136	182	220	226	240	257
EMERGENCY VENT	IN	3	3	4	4	4	4

TOP VIEW

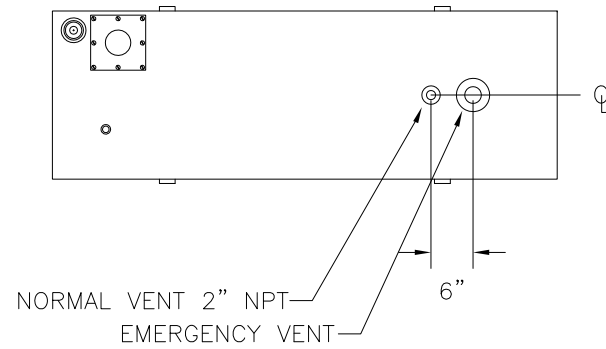

FRONT VIEW

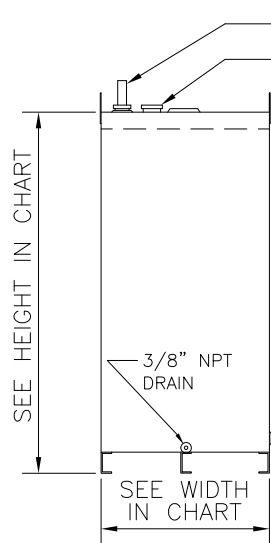

RIGHT SIDE VIEW

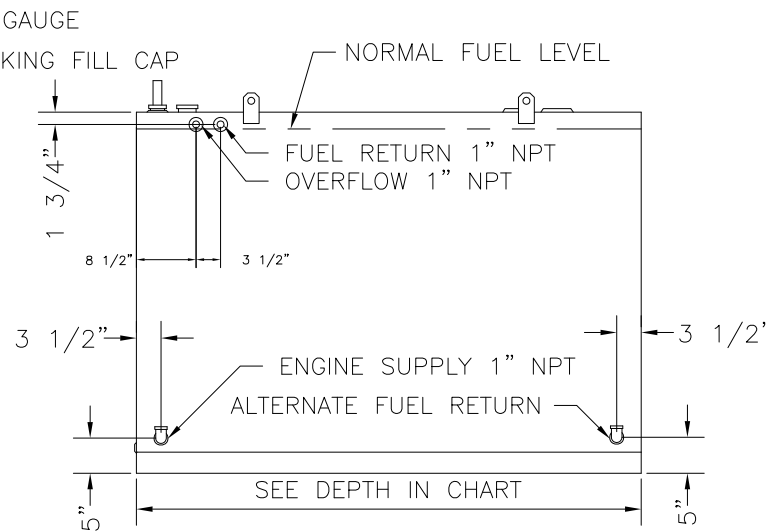

REAR VIEW



				E & C A			
				SCALE NONE	APPROVED BY		DRAWN BY: TMP
				DATE 2-14-91			REVISED
2	7-12	MOVED NORMAL VENT TO TOP	MEP	FT150	FT200	FT275	FT325 FT350
1	10-94	ADDED EMERGENCY VENT	TMP	UL DESIGN FUEL TANK			DRAWING NUMBER
REV	DATE	DESCRIPTION	BY				02205