

TOP VIEW

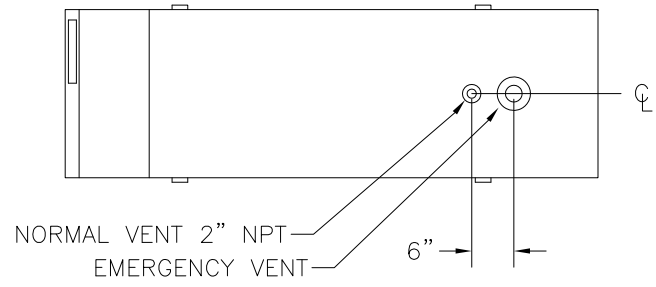

MODEL

		DT150	DT200	DT275	DT300	DT325	DT350
CAPACITY	GAL.	150	200	275	300	325	350
	LIT.	570	758	1041	1136	1230	1325
WIDTH	IN	24	24	24	24	28	24
	CM	61	61	61	61	71.1	61
DEPTH	IN	36	48	60	65	60	76
	CM	91.4	121.9	152.4	165	152.4	190.5
HEIGHT	IN	55	59.5	59.5	59.5	59.5	59.5
	CM	139.7	151.1	151.1	151.1	151.1	151.1
WEIGHT	LB	336	438	521	535	567	602
	KG	153	200	237	243	258	274
NORMAL VENT	IN	2	2	2	2	2	2
EMERGENCY VENT	IN	3	3	4	4	4	4

FRONT VIEW

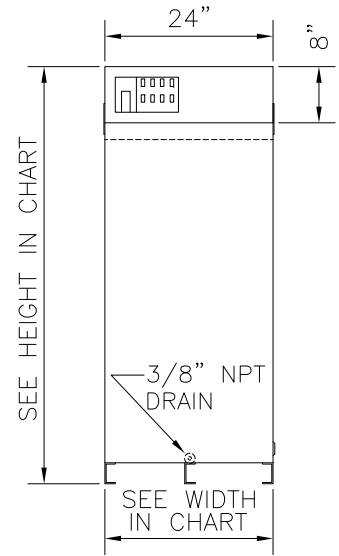

RIGHT SIDE VIEW

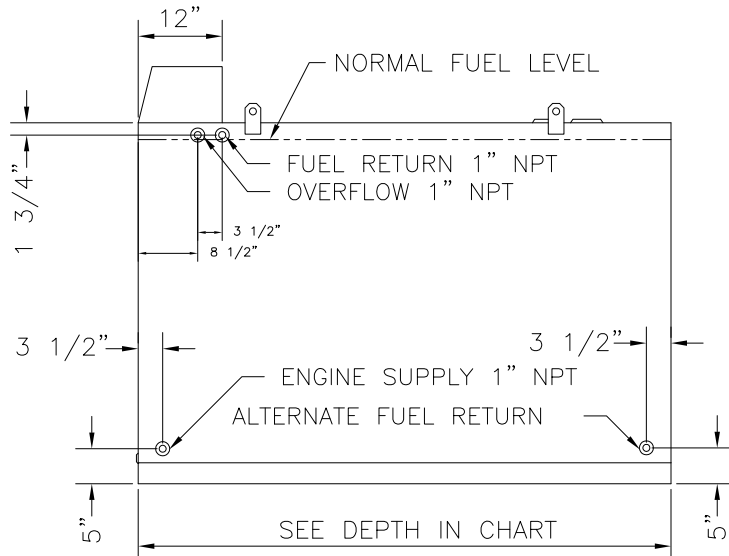

REAR VIEW

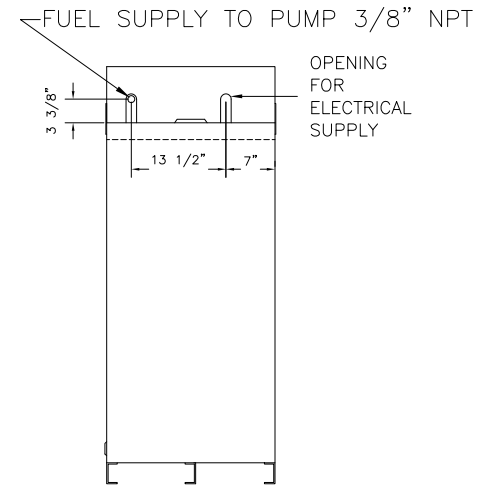

				E & C A			
		SCALE NONE		APPROVED BY		DRAWN BY: TMP	
		DATE 6-26-90				REVISED	
3	12-11	MOVED NORMAL VENT TO TOP	ABC	DT150 DT200 DT275 DT325 DT350			
2	6-08	REMOVED HIGH/LOW ALARM LEVELS	KNA				
1	2-91	ADDED DT150 & DT200	TMP				
REV	DATE	DESCRIPTION	BY	UL DESIGN DAY TANK			DRAWING NUMBER 02064