

FRONT VIEW

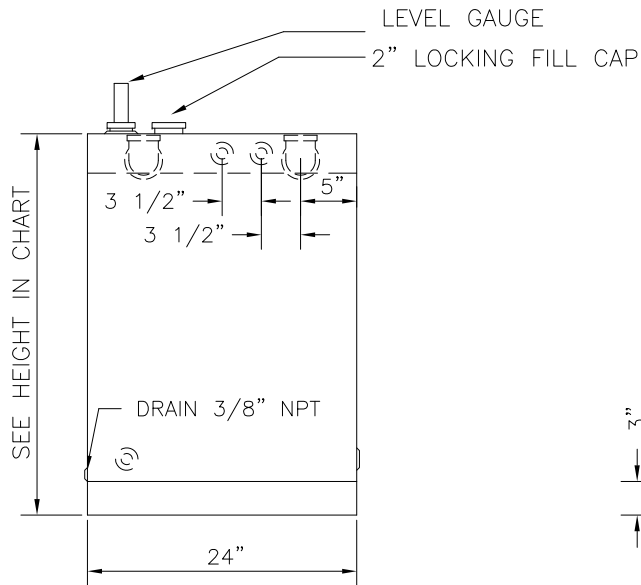

RIGHT SIDE VIEW

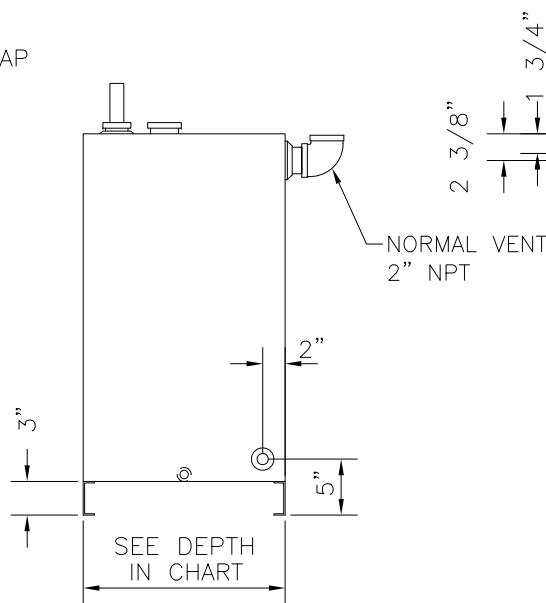

REAR VIEW

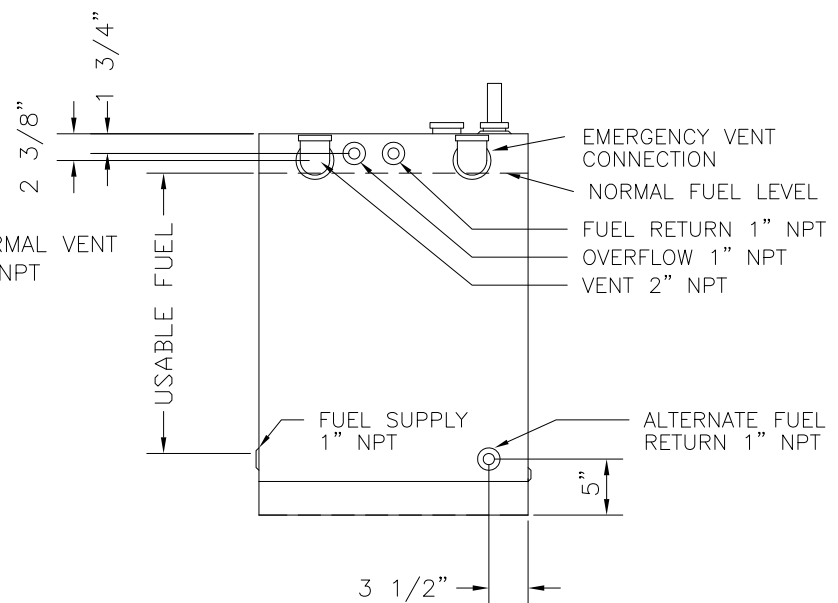

		MODEL					
		FT50	FT60	FT75	FT100		
CAPACITY	GAL.	50	60	75	100		
	LIT.	189	228	284	379		
WIDTH	IN	24	24	24	24		
	CM	61	61	61	61		
HEIGHT	IN	34	39	47	47		
	CM	86.4	99.1	119.4	119.4		
DEPTH	IN	18	18	18	24		
	CM	45.7	45.7	45.7	61		
WEIGHT	LB	125	129	158	183		
	KG	57	59	71.6	83		
EMERGENCY VENT	IN	2	2	2	3		



E & C A		
SCALE NONE	APPROVED BY	DRAWN BY: TMP
DATE 12-20-86		REVISED
MODEL FT50, 60, 75, 100ULD		
UL DESIGNED TANK		DRAWING NUMBER 01425

REV	DATE	DESCRIPTION	BY
3	7-12	CHANGED VENT TO 2" NPT	MEP
2	5-00	MOVED EMERGENCY VENT TO BACK	TMP
1	12-94	GENERAL	TMP